

COMPARACIÓN DE CÓDIGO ACTUAL Y PROPUESTA

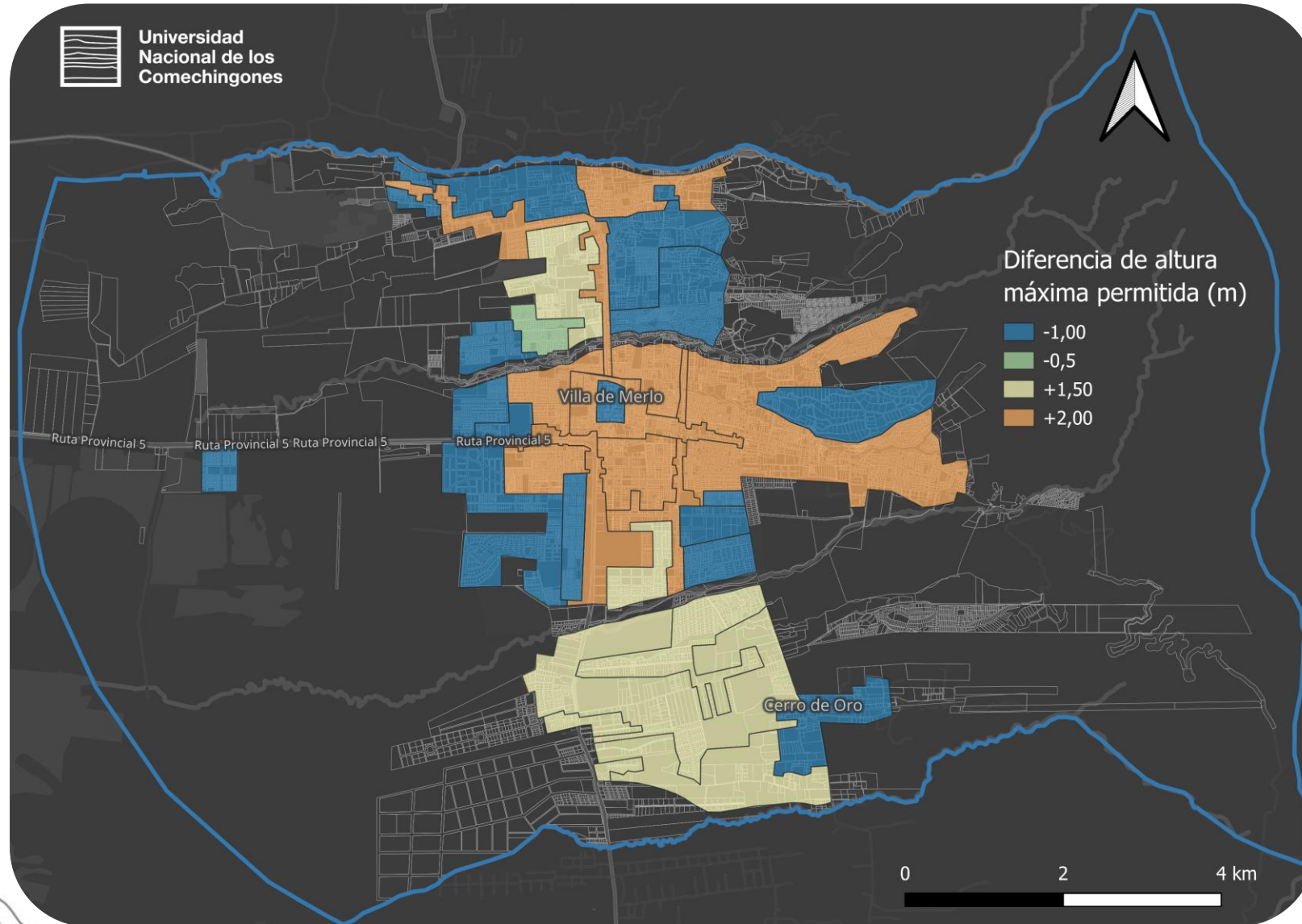

COMPARACIÓN DE CÓDIGO ACTUAL Y PROPUESTA

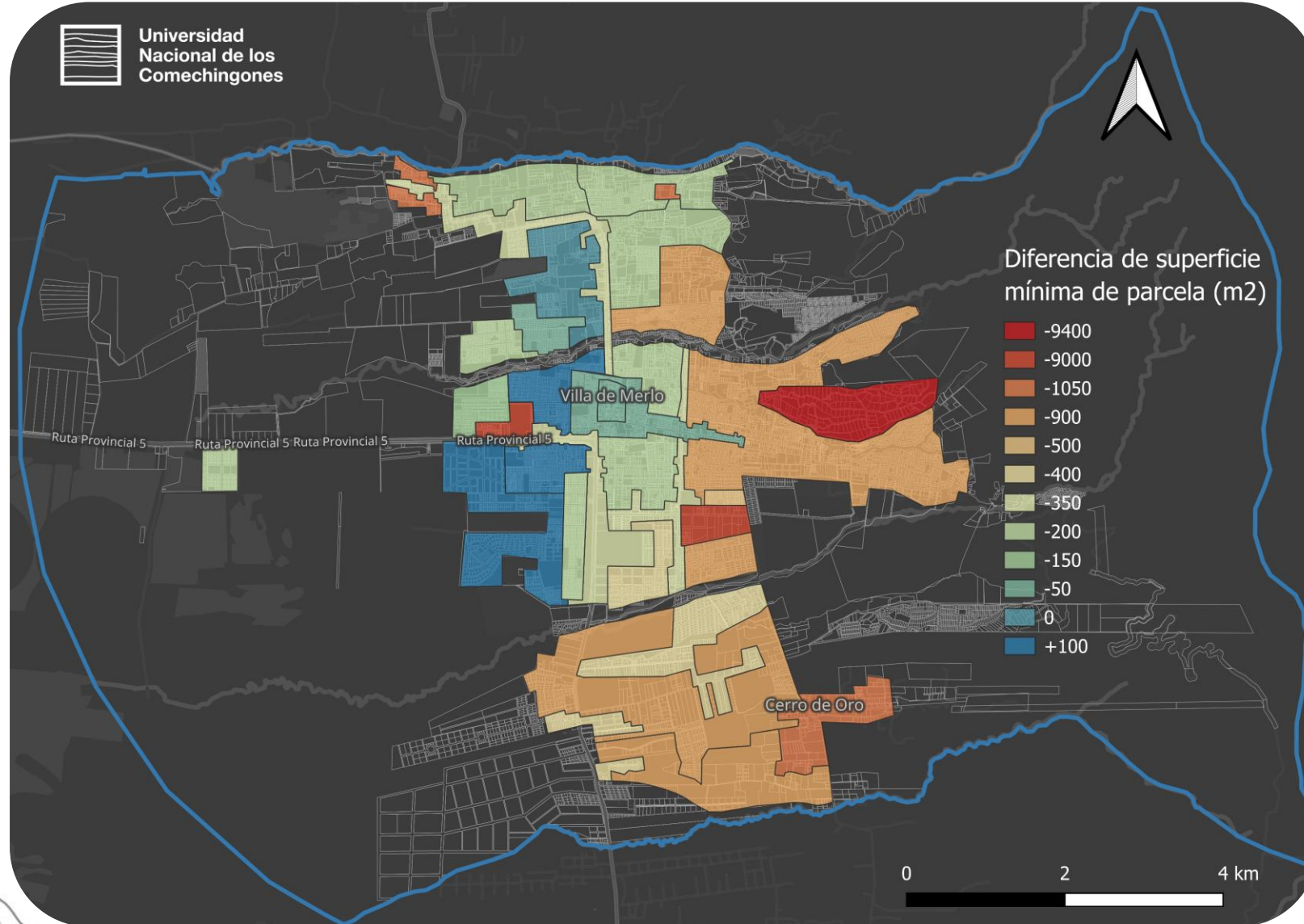

COMPARACIÓN DE CÓDIGO ACTUAL Y PROPUESTA

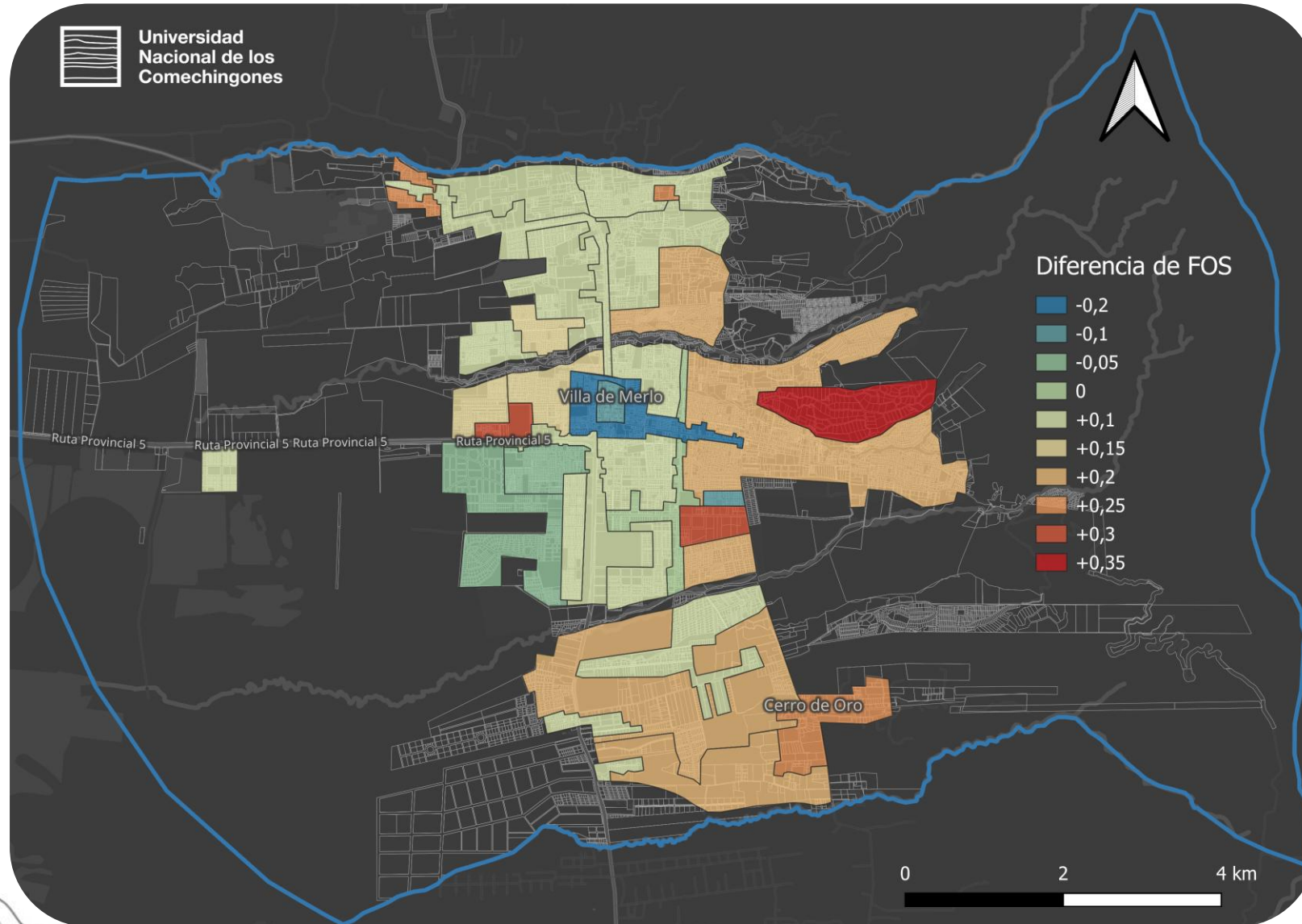

COMPARACIÓN DE CÓDIGO ACTUAL Y PROPUESTA

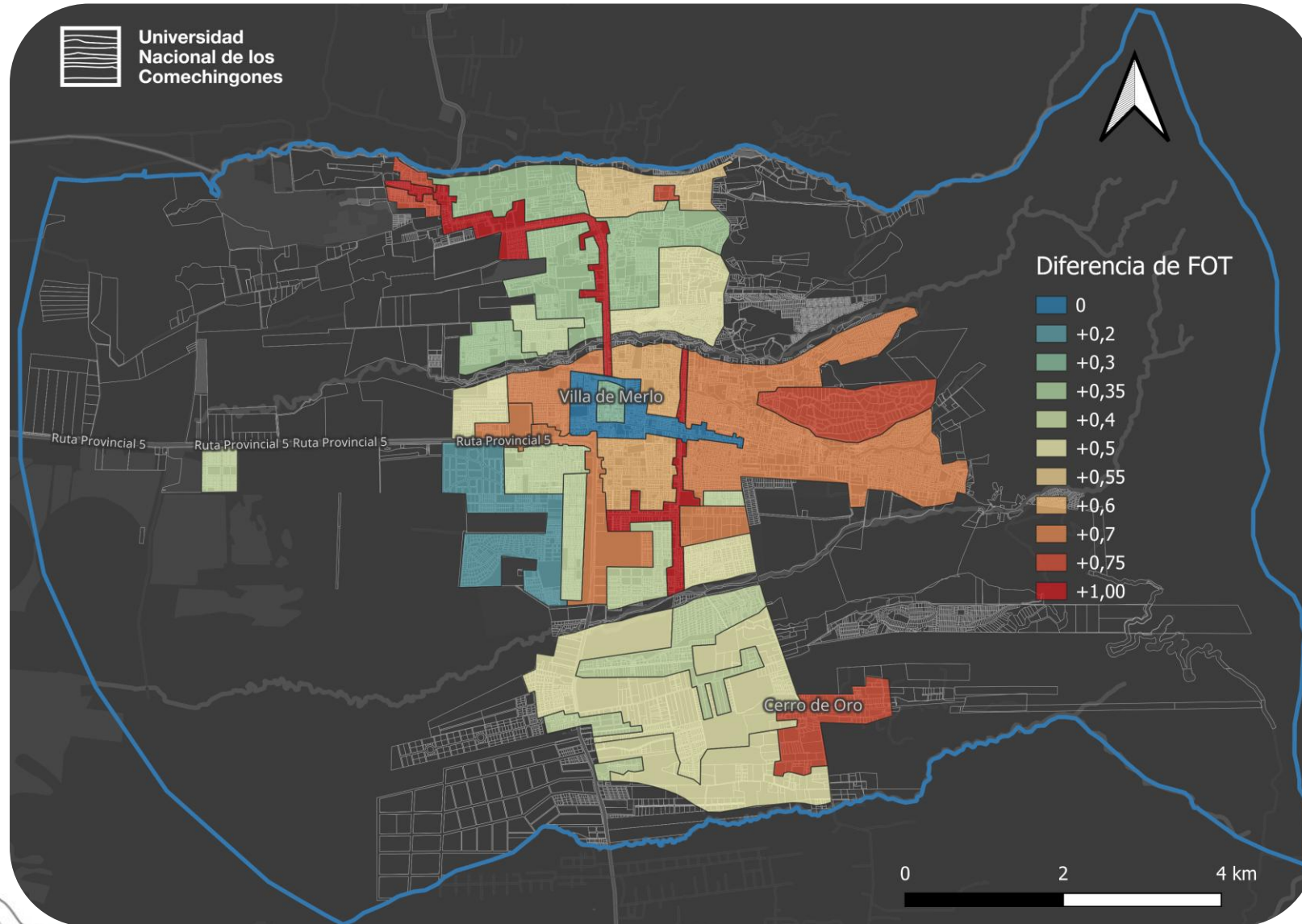

CERRO DE ORO – CENTRO ZONAL



INDICADOR	744/2000	PROPUESTA
Altura máxima	10,00m	9,00m
Superficie mínima	1.500m²	400m²
FOS	0,15	0,40
FOT	0,25	1,00

Parcela de 1.200m²
480m² en PB
1.200m² total

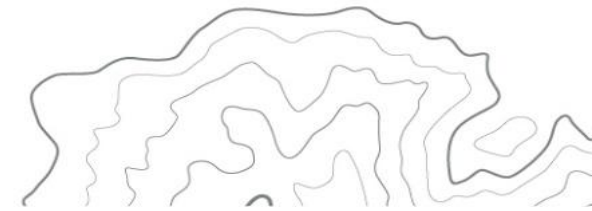
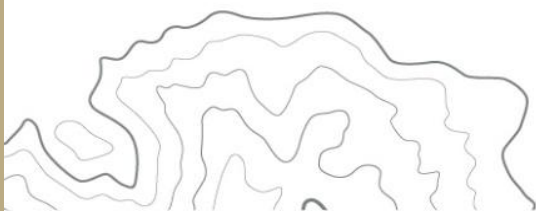
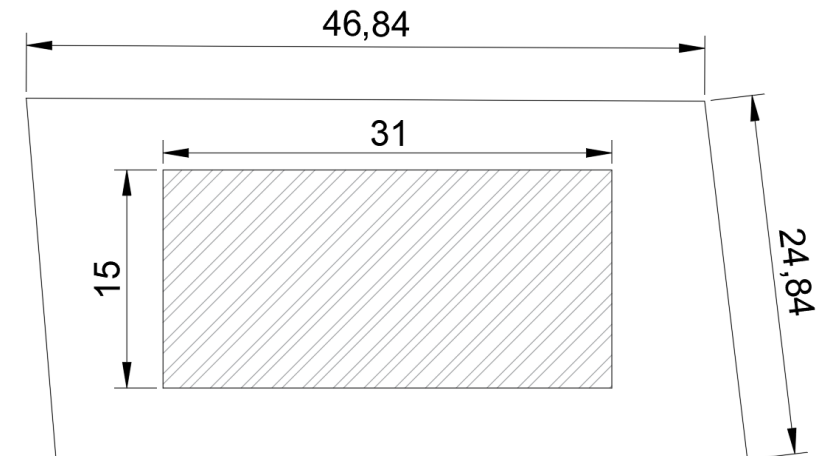

CERRO DE ORO – CENTRO ZONAL



INDICADOR	744/2000	PROPUESTA
Altura máxima	10,00m	9,00m
Superficie mínima	1.500m²	400m²
FOS	0,15	0,40
FOT	0,25	1,00

Parcela de 1.200m²
480m² en PB
1.200m² total

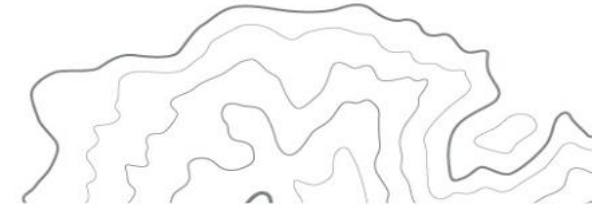
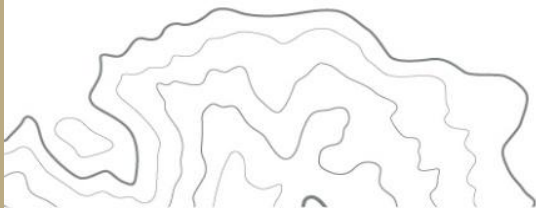
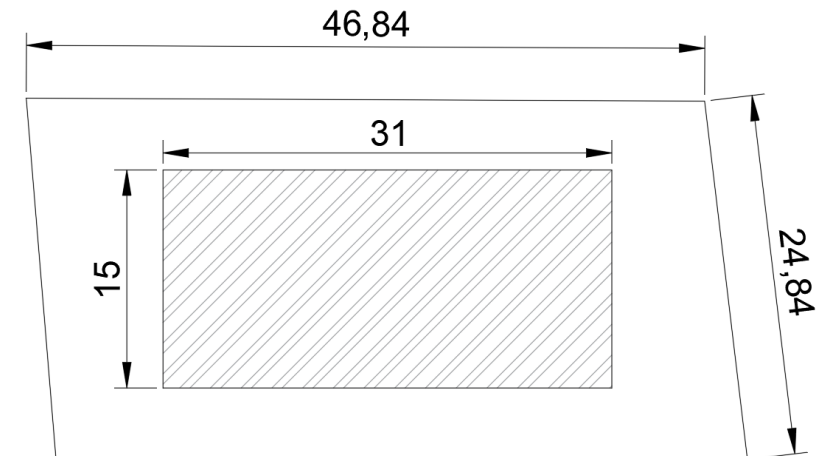

CERRO DE ORO – CENTRO ZONAL

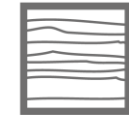

Universidad
Nacional de los
Comechingones



CERRO DE ORO – CENTRO ZONAL

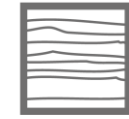

Universidad
Nacional de los
Comechingones



LOS NOGALES – PERIFERIA 1



Parcela de 6.000m²
2.400m² en PB
4.800m² total

INDICADOR	744/2000	PROPUESTA
Altura máxima	10,00m	9,00m
Superficie mínima	10.000m²	600m²
FOS	0,05	0,40
FOT	0,05	0,80

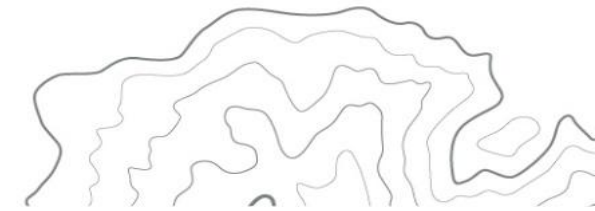
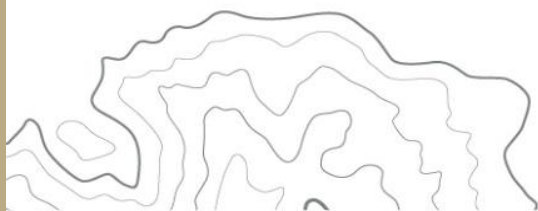
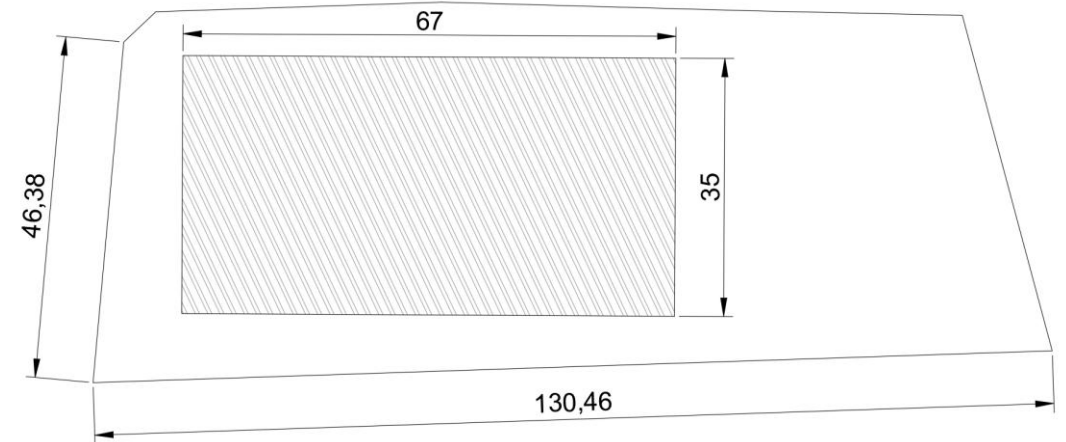

LOS NOGALES – PERIFERIA 1

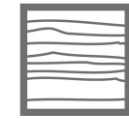

Universidad
Nacional de los
Comechingones

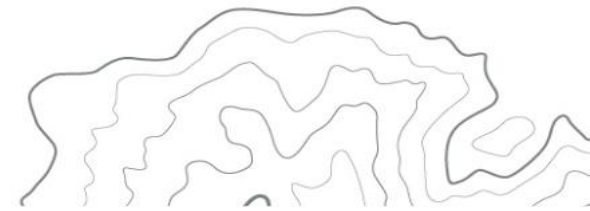
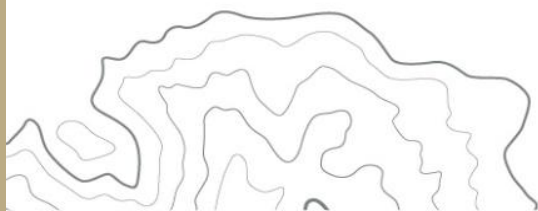

LOS NOGALES – PERIFERIA 1

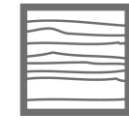

Universidad
Nacional de los
Comechingones

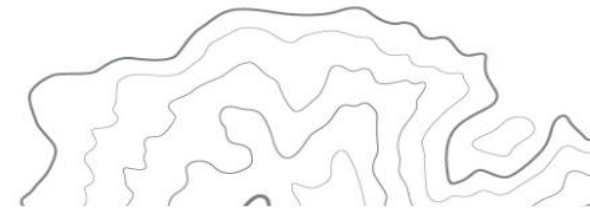
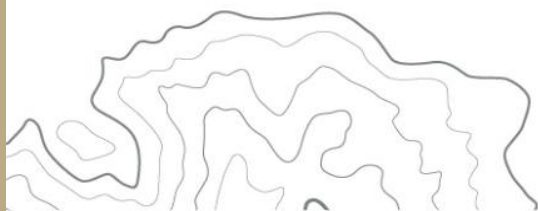

AV. NORTE Y AV. FERMÍN ROMERO CENTRO EXPANSIÓN 1

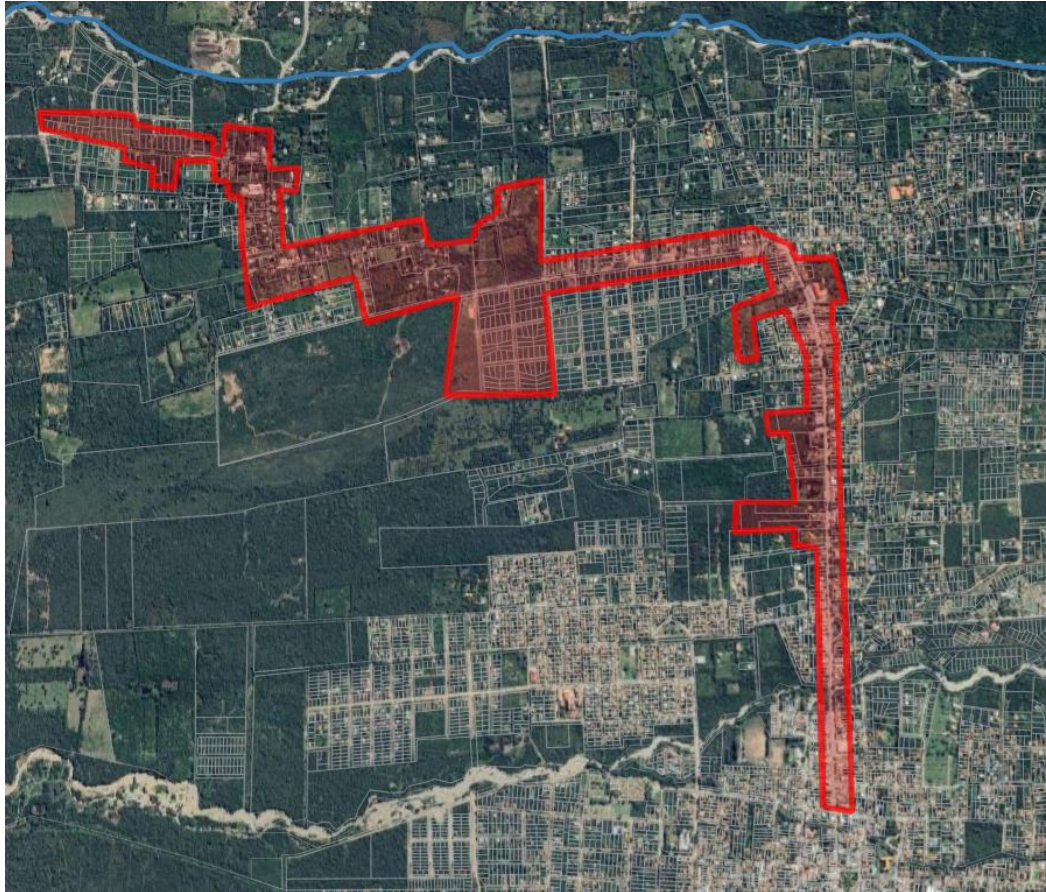

INDICADOR	744/2000	PROPUESTA
Altura máxima	10,00m	12,00m
Superficie mínima	800m ²	450m ²
FOS	0,50	0,60
FOT	0,80	1,80

**Parcela de 800m²
Av. Fermín Romero
480m² en PB
1440m² total**

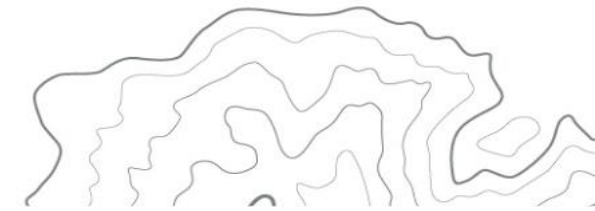
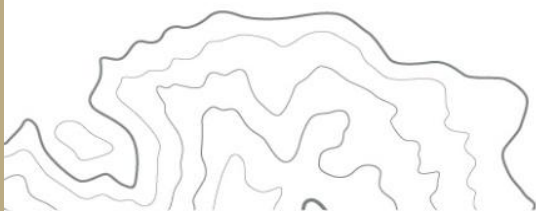
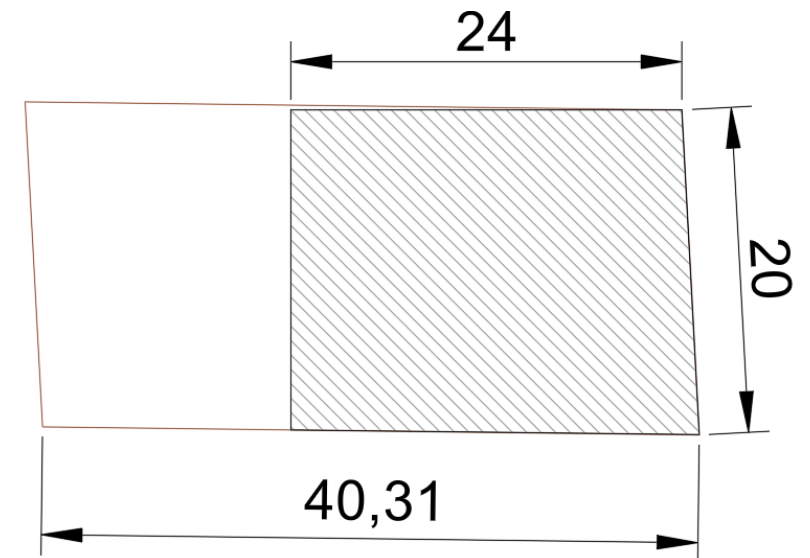

AV. NORTE Y AV. FERMÍN ROMERO CENTRO EXPANSIÓN 1

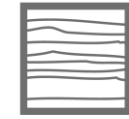

Universidad
Nacional de los
Comechingones



© 2020 Google

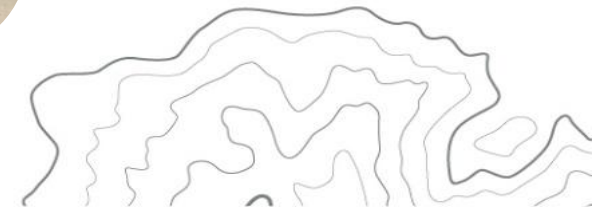
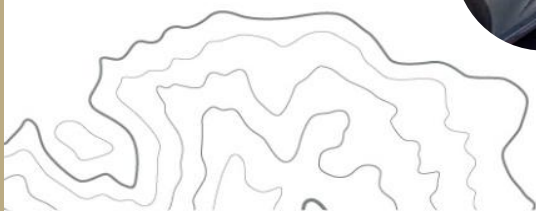

RUTA N°1 y N°5 – CENTRO EXPANSIÓN 2

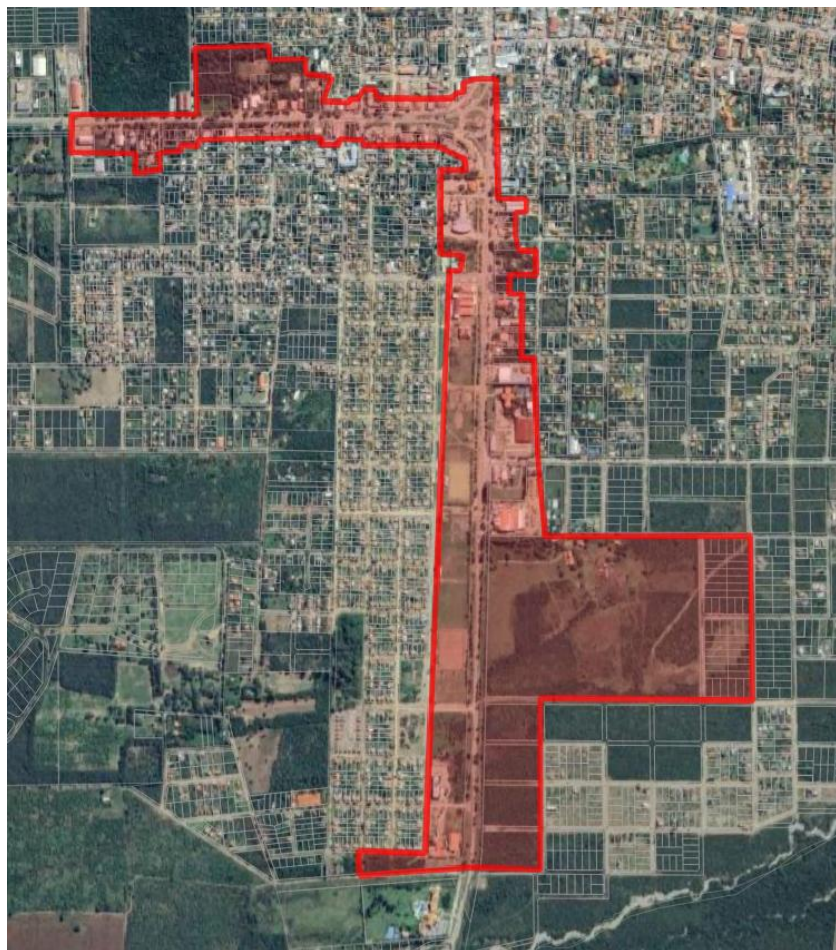

INDICADOR	744/2000	PROPUESTA
Altura máxima	10,00m	9,00m
Superficie mínima	800m²	450m²
FOS	0,50	0,60
FOT	0,80	1,50

Parcela de 450m²
270m² en PB
675m² total

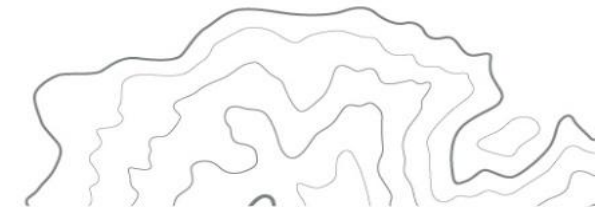
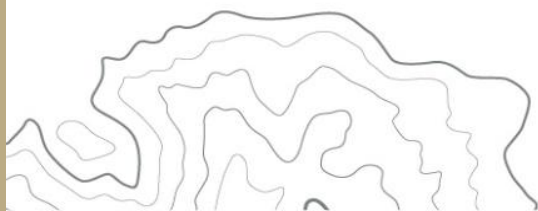
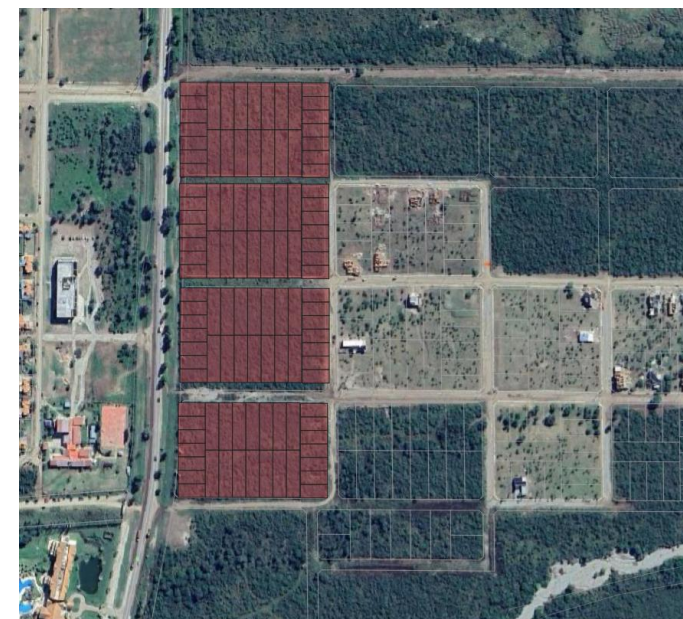

RUTA N°1 y N°5 – CENTRO EXPANSIÓN 2

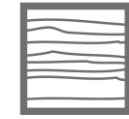

Universidad
Nacional de los
Comechingones

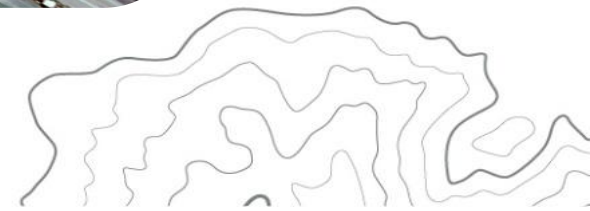
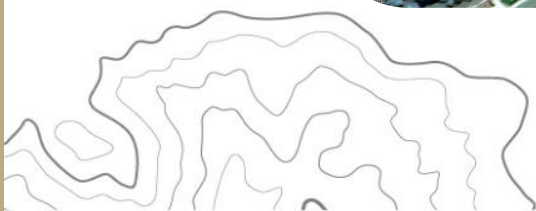
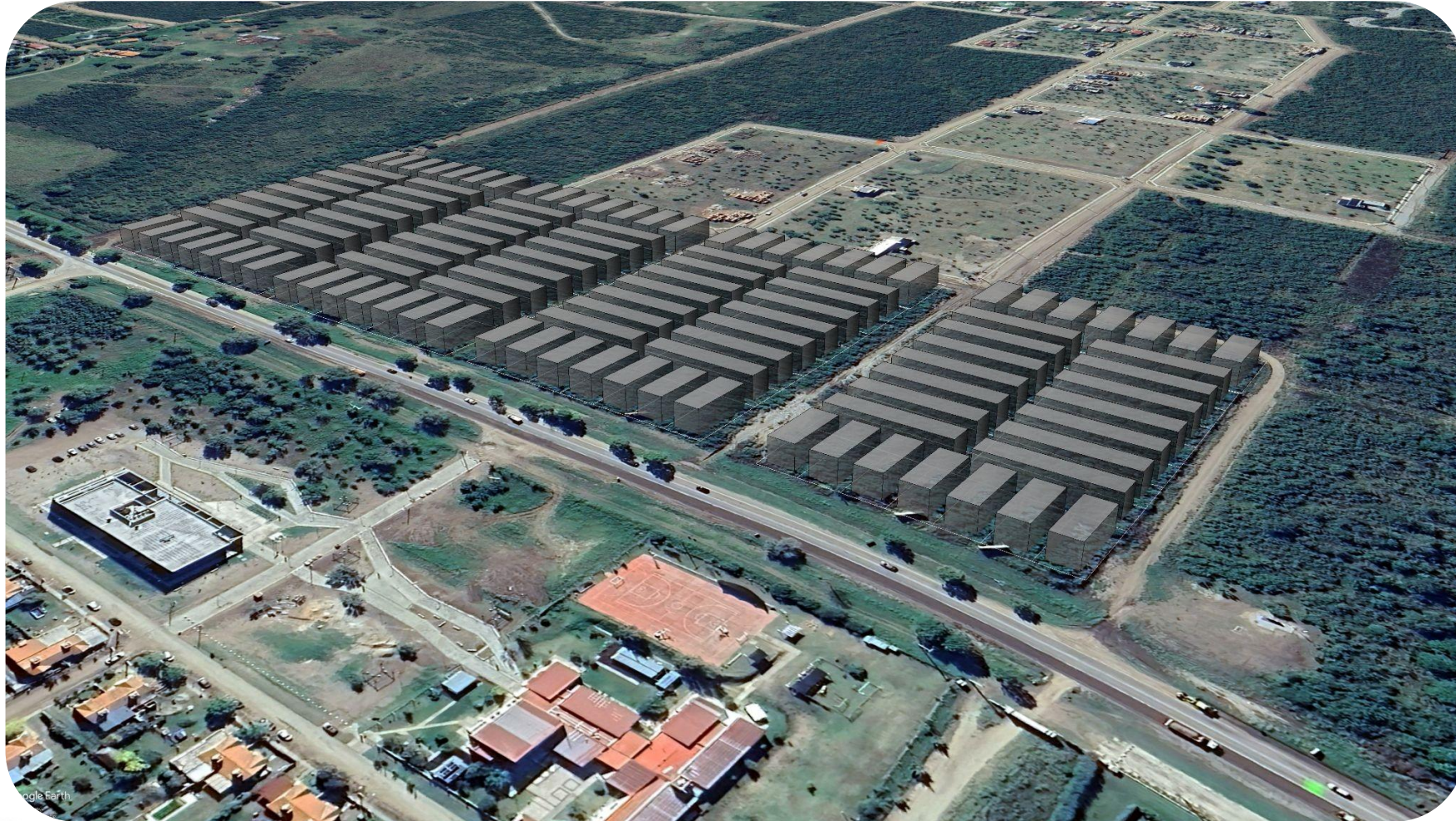

RUTA N°1 y N°5 – CENTRO EXPANSIÓN 2

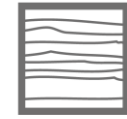

Universidad
Nacional de los
Comechingones

